

GEM LAKES ESTATES ASSOCIATION
AIKEN, SOUTH CAROLINA

REPORT ON
EXISTING PRIVATE DOCKS

June, 2002

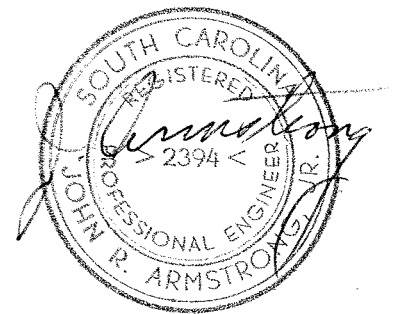

JOHN R. ARMSTRONG
PROFESSIONAL ENGINEER
988 Campbellton Drive
North Augusta, SC 29841

REPORT ON EXISTING DOCKS
Gem Lakes Estates Association, Aiken, S. C.

The ten existing docks located within the Gem Lakes subdivision were visually inspected during May and June, 2002 for the purpose of evaluating the general condition of the docks, estimating load capability, and making recommendations of changes or improvements needed. In addition, the Association's policy has been reviewed and some structural recommendations are included in this report.

Most of the existing docks vary to some degree from the requirements of the **Gem Lakes Estates Dock Management Program** specifications. Details of the individual docks are attached to this report in a one page format for each dock. Structural requirements for docks under the Association's design specifications are very limited; a few requirements could be helpful if added without making the document cumbersome. Because all of these docks are private, I know of no code requirements to which you must adhere. The following are suggestions which likely will benefit owners in the construction or repair of their docks.

- Southern Yellow Pine (SYP) treated with Chromated Copper Arsenate (CCA) currently is the most effective and economical material now available for construction of docks. No.1 and No.2 SYP are acceptable for the decking. No. 1 is preferred for the supporting framing because the knots are smaller and are less likely to affect members which need to have individual integrity. Because of the arsenic content, CCA treatment is being voluntarily removed by the industry from residential uses of treated wood. EPA **has not** determined that unreasonable risks are posed to the public from the use of CCA treated wood around or near homes; the products will continue to be available until December 31, 2003. CCA treatment levels are available at 0.25 #/cf, 0.4 #/cf, 0.6 #/cf, and 0.8 #/cf; the higher treatment levels substantially extend the useful life of the timber.
- The minimum live load used for the floors of most residences is 40 #/sq ft. Also it is a satisfactory design minimum for the supporting timbers of these docks. The deck timbers should be designed for a much higher load capacity than the supporting framework because the individual deck timber frequently carries the weight of a man standing on one foot at the center of the span. Decking of 2x4's supported by joists @ 24 " o. c. and 5/4 x 6's supported by joists at 20 " o. c. will provide that support capability.
- Deck timbers wider than 6" should not be used because sun curl has such a magnified effect on boards wider than 6"; sun curl, usually is not significant in 4" wide material.
- The spacing of joists should be held within the 16" to 24" range. Narrow spacing reduces longitudinal warping of the deck timbers as well as improves the load capacity of the decking.
- The use of galvanized nails, lag screws, and bolts provides a sacrificial coating which extends the life of the fasteners. The use of screw nails to attach deck planks can cause problems: except for center nailing, sun curl likely will pull the screw nails and the screws will retain the deck curl. Standard nails are much easier to reset because the nailheads become raised. Galvanized bolts and lag screws should be used for attachment to supporting posts unless stainless steel is available.
- Buoyancy of the wood docks can be offset by the friction of driven pipe, wood posts, or by providing sufficient submerged weight. To offset the buoyancy, the Pipe friction in the soil that is adequate to support the design loads of the dock also is usually adequate to resist the uplift. An alternative is to provide 2 # of submerged weight for each board foot of timber in the dock; concrete will provide approximately 80 # of submerged weight per cubic foot of concrete.

At the time of the dock inspection, an estimate was made of the age and condition of the timber in each of the docks and a bending stress consistent with that estimate was used to evaluate the load capacity of the dock. In each case, the timber believed to be limiting the remaining load capacity of the structure was identified and indicated on the report sheet of that dock. Substructure load capacity of 15#/sq ft was identified for several of the docks. These docks have a low support capability but are not necessarily unsafe for modest use. Usually minor changes in the support framing would substantially increase the allowable load of the dock. A load capability of 15 #/sq ft likely is the lowest capacity which should continue to be used by an individual owner without some reconstruction work to increase the allowable load. When design, age, decay, or damage results in a capacity less than 15#/ sq ft your association guidelines should recommend repair to raise the allowable load back up to 40 #/sq ft or greater.

The docks are located at the shoreline of the owner's property and provide relatively easy access to deeper water for the owners, guests, and trespassers. Only one dock was posted with a "NO SWIMMING" sign.

The following docks were inspected; a one page report is attached in the following alphabetical order:

- Joe & Ruth Alexander
- Allen & Sally Brodie
- James F. & Ann C. Kauffman
- John Koonce
- Jerry E. & Hattie C. McCarty
- Harry & Linda Nadal
- William R. & Pauline Penland
- W. James & Judy Rivers
- Don & June Roseborough
- Dan Wood & Malcolm Kyle

The recommendations which appear on the individual dock sheets should substantially extend the useful life of these docks.

**GEM LAKES ESTATES
DOCK MANAGEMENT PROGRAM
FIELD DATA: date 5/10/2002**

NAME AND ADDRESS OF OWNER: Joe & Ruth Alexander

226 Springwood Drive

Aiken, S. C. 29803

Sketch: yes

Date of original application: 3/16/98

Plans on file: yes ;

Photograph: no

DOCK SIZE & ORIENTATION: width at shore: walkway 4 ft; dock width 14 ft;

Projection from shore: walkway length 12 ft-3 in; dock length 18 ft; total projection: 30.2 ft.

Ht above water 3 ft 1 in. Size & location of handrails: all around: 3 ft high w/ pickets at 5 1/2" o.c.
2x4 kick boards all around railings.

Other above dock construction: Hipped roof rain shelter w/ceiling

DOCK CONSTRUCTION: type of materials and treatment No. 1 SYP treated w/.25 #/c. f. CCA

Estimate of age and condition of materials: 5 yrs. good condition: Use f=1050 psi in bending.

Dock & walkway:

Deck planks: 5/4 x 5 1/2 @ 5 3/4" span: 16" connect. 2 - 8d galv; walkway same as Dock.

Joists: size x spcng 2x10 @ 16"; span: 7 ft + 4 ft cantl; walkway joists @ c/l: 2x10 @ 24" span 7 ft & 5 ft

Connect. Joists to header: 1 1/2 x 1 1/2 ledgers @ center header of 2 - 2x10's spanning 7 ft; Connect. header to center 4x4 post is let in by 1 1/2"; Sleeper @ cantilever is dropped down below joists which bear on top of the 2 - 2x10's; span of sleeper is 4'-6" (three spans).

Exterior headers: 2 - 2-10's around the perimeter. Joists are supported on ledgers.

Supports; piling: 11 - 4x4 posts; 3 galv nails at let-in conn of headers to posts.

SKETCH OF DOCK FACILITY

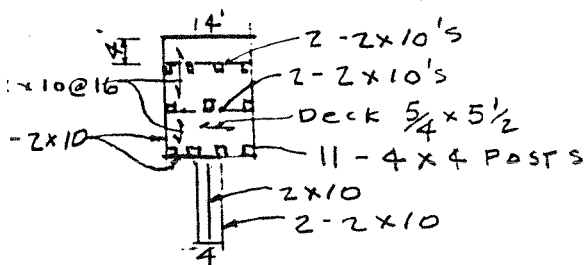

COMMENTS:

The center header of 2 - 2x10's spanning 7 ft
Is the member limiting the design capacity
of this dock to 75 lbs/ sq. ft.

ALEXANDER DOCK 5-10-02

**GEM LAKES ESTATES
DOCK MANAGEMENT PROGRAM
FIELD DATA: date 6/21/2002**

**NAME AND ADDRESS OF OWNER: Allen & Sally Brodie
457 Town Creek Church Road
Aiken. S. C. 29803**

Date of original application: None; plans on file: no; Photograph: no

DOCK SIZE & ORIENTATION: width at shore: 12 ft; dock length: 16ft- 2 in.;

Total projection from shore: 9 ft; Ht above water: 2' - 0"; Size & location of handrails: none.
Other above dock construction: none

DOCK CONSTRUCTION: type of materials and treatment: No. 1 SYP treated w/ CCA

Estimate of age and condition of materials: 15 yrs; for decking, use $f'' = 1050$; for joists, use 1020 psi.

Deck planks: 5/4 x 5 1/2 @ 5 3/4" o. c. span: 24 inches connections: 2 - 8d galv. nails ea joist.

Joists: size x spacing: 2x 8 @ 24" span: 12 ft . Connections: Joists to header: 3 - 20d galv nails.

Headers: size x spacing: 2x8, max span = 5' - 2", three span condition.

Supports; nine 4x6 piling; connection to supports: 3 - 20d galv. nails @ ea header or joist.

SKETCH OF DOCK FACILITY

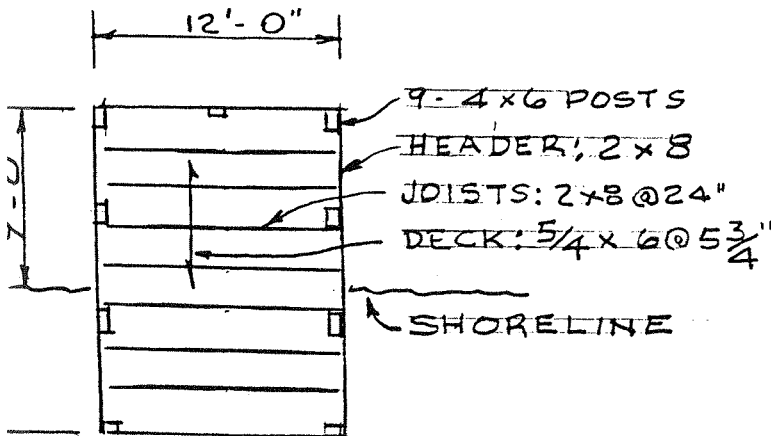

COMMENTS:

The 2x8 joists spaced at 24" oc & spanning 12 ft. are the members limiting the allowable load of this dock to approximately 30 lbs/sf. The headers have a comparable load capability. While the decking is beginning to show the effects of sun and age, it should continue to perform satisfactorily until more decay is evident.

**GEM LAKES ESTATES
DOCK MANAGEMENT PROGRAM
FIELD DATA: date 6/4/2002**

NAME AND ADDRESS OF OWNER: James F. & Ann C. Kauffman
241 Lakeside Drive
Aiken, SC 29803

Date of original application: 3/16/98 ; plans on file: yes; Photograph: no; Sketch: yes.

DOCK SIZE & ORIENTATION: width: 16' - 1 1/2"; Dock length: 10' - 9" Walkway width: 3' - 11 1/2".
Walkway length: 22' - 4"; total projection 32' +/-; Ht above water 12" +/-; The four pipe supports on the lake side project approximately 18" above the dock as rod holders.

DOCK CONSTRUCTION: type of materials and treatment: No. 2 SYP treated w/ 0.25 #/ cu ft of CCA.
Estimate of age and condition of materials: 2 years in good condition; use f= 1050 psi in bending.

DOCK MATERIALS:

Deck planks: 5/4 X 5 1/4" @ 5 3/4" oc span: 1'-9"; connect : 2 - 8d galv screws @ ea support.

Joists: size x spacing : 2x6 @ 21" dock & 2x6 @ 1' 11 1/2." walkway; span @ dock: 5' - 7", 3 spans; span @ walkway 7' - 6"; connection of joist to headers: galv steel clips. The center 2x6 joist also supports the 2x4 cross bms connected with the galv metal clips.

Dock sleepers: 2x4's @ 1/3 points (span 5' - 3"); 2x8 header @ dock/walkway interface (span 5' - 0");
Connection of 2x4's to 2x8 header w/ 3/8 " diam lag bolt each end.

Supports: 8 - 2" O D steel posts, 2 - 2 1/2 O D posts & 4 - 2 3/8" OD posts. One center wood 4x4 post.
Connection of the 2x8 perimeter members to the pipe supports is with 2 - 1/4" U - bolts at ea steel post.

SKETCH OF DOCK FACILITY

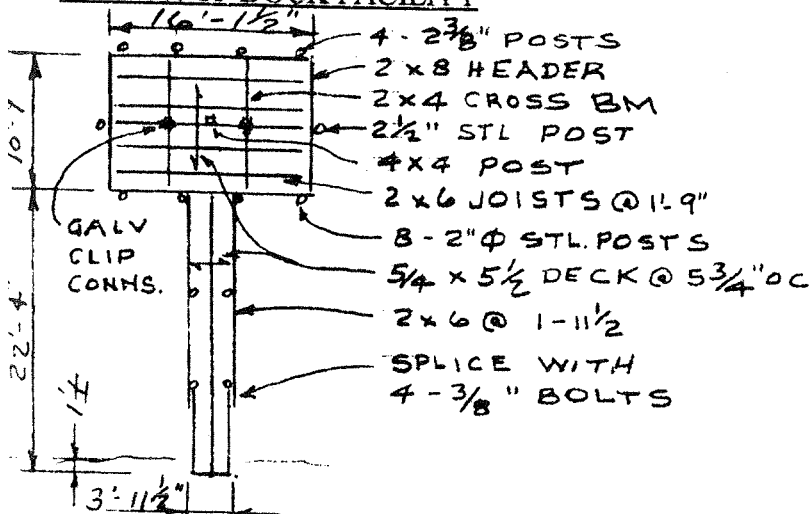

COMMENTS:

The 2x6 center joist and the 2x4 cross beams are the members limiting the design capacity of this dock to 15 #/ sq ft. Doubling the 2x6 center joist and the 2x4 cross beams would double the design capacity of the dock.

**GEM LAKES ESTATES
DOCK MANAGEMENT PROGRAM
FIELD DATA: date 6/4/2002**

NAME AND ADDRESS OF OWNER: John Koonce
237 Lakeside Drive
Aiken, SC 29803

Date of original application: 3/16/98 ; plans on file: yes; Photograph: no; Sketch: yes.

DOCK SIZE & ORIENTATION: width: 19 - 9"; Dock length: 8' - 1". Walkway width: 3' - 4";
Walkway length: 25' - 10"; total projection 27' +/- ; Ht above water 8"+/-; there is no above dock construction.

DOCK CONSTRUCTION: type of materials and treatment: No. 2 SYP treated w/ 0.25 #/ cu ft of CCA.
Estimate of age and condition of materials: 15 years in fair condition; use f= 630 psi in bending for the deck; use f = 788 psi in bending for the joists.

DOCK MATERIALS:

Deck planks: 2x4 @ 4" oc span: 3'-5"; connect : 1 - 8d galv nail @ ea support.

Joists: size x spacing : 2x6 @ 42" dock & 2x6 @ 40" walkway; span @ dock: 5' - 0"; span @ walkway 4' max; connection of joist to headers: 2 - 10d galv nails. Connection to pipe supports: 2 - 1/4" bolts.

Dock headers @ 1/4 points: combined section of 2x6 & 2x4 deck plank cap (span 7' - 0").

Supports: 8 - 4x4 wood posts & 16- 2 1/2 O D steel posts. Connection of the 2x6 perimeter members to the pipe supports is with 2 - 1/4" bolts at ea. steel post.

SKETCH OF DOCK FACILITY

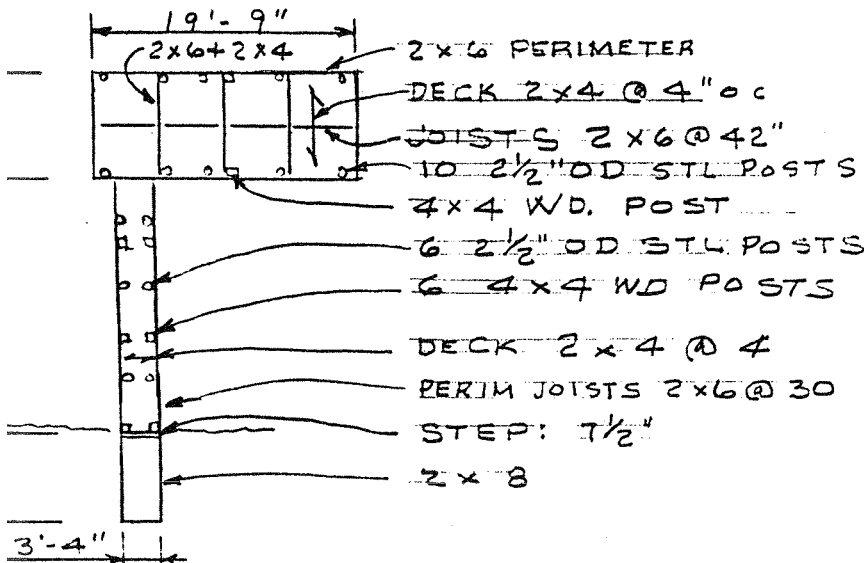

COMMENTS:

The combined section header (2x6 w/2x4 cap) cross beams are the members limiting the design capacity of this dock to 30 #/ sq ft. Deck planks also are highly stressed; When the deck is replaced, add additional 2x6 joists to reduce the deck plank span to 21".

**GEM LAKES ESTATES
DOCK MANAGEMENT PROGRAM
FIELD DATA: date 5/25/2002**

NAME AND ADDRESS OF OWNER: Jerry & Hattie C. McCarty
104 Recreation Drive
Aiken, SC 29803

Date of original application: 3/16/98 ; plans on file: yes; Photograph: no; Sketch: yes.

DOCK SIZE & ORIENTATION: width: 7' - 9"; Dock length: 8' - 5". Walkway width: 3' - 0";
Walkway length: 23' - 1"; total projection 31' - 6" ; Ht above water 16"; There is no above dock constr.

DOCK CONSTRUCTION: type of materials and treatment: No. 1 SYP treated w/ 0.25 #/ cu ft of CCA.
Estimate of age and condition of materials: 6 years in good condition; use $f = 1050$ psi in bending.

DOCK MATERIALS:

Deck planks: 5/4 X 5 1/4" @ 5 1/2" oc diagonal; span: 1'-9"; connect : 2 - 8d galv nails @ ea support.

Joists: size x spacing : 2x6 @ 15" dock & 2x6 @ 17 1/2" walkway; span @ dock: 8' - 0"; span @ walkway 11' - 6"; connection of joist to headers: galv steel seat clips w/ 2 - 8d galv nails ea side of joist.

Headers: 2 - 2x6's @ outer edge (span 7' 0"), @ dock/walkway interface (span 7' 0"), & @ center of walkway length (header span 3' - 0"). Headers bear on concrete filled block piers.

Supports: 6 conc filled block piers reinforced w/ 2 #4 re-bar, ea pier. Connection of header to each pier is with a 1" wide x 1/8" thick stn stl strap nailed to the header with galv nails.

SKETCH OF DOCK FACILITY

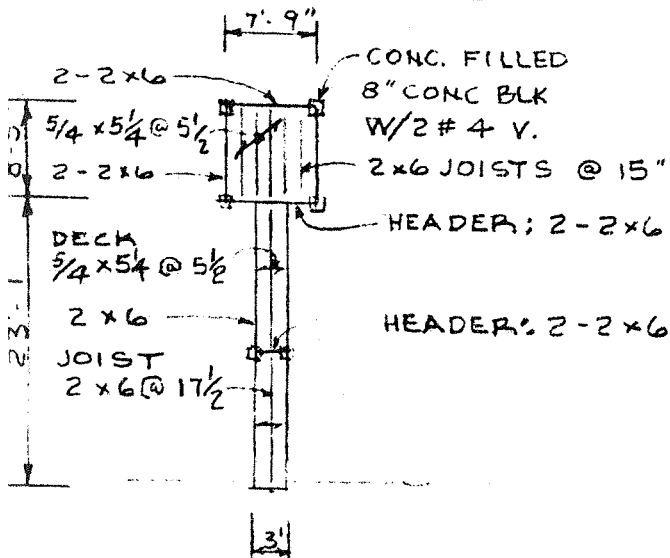

COMMENTS:

The 2 - 2x6 header at the walkway/ Dock interface spanning 7' - 0" is the member limiting the design capacity of this dock to 25#/ sq. ft.

**GEM LAKES ESTATES
DOCK MANAGEMENT PROGRAM
FIELD DATA: date 5/25/2002**

NAME AND ADDRESS OF OWNER: Harry & Linda Nadal
102 Recreation Drive
Aiken, S. C. 29803

Date of original application: None; plans on file: No.

DOCK SIZE & ORIENTATION: width: 6' - 0"; Dock length: 7' - 3". Walkway width: 4' - 5";
Walkway length: 2' - 4". Total projection: 10' - 2"; Ht. above water: 14". No Above dock Constr.

DOCK CONSTRUCTION: type of materials and treatment: No. 1 SYP treated w/ CCA.
Estimate of age and condition of materials: 8 years +/-, in fair condition; use f= 840 psi in bending.
One deck plank is decayed; one side joist is showing slight decay in top surface. There is some corrosion of the bolts connecting the joists to the PVC posts.

DOCK MATERIALS:

Deck planks: 2x4 @ 4" oc. span :3' & 1.5' cantilever overhang; conn: 2 - 8d nails @ ea support.

Joists: size x spacing : 2x6 ea. side @ 3'; max span: 9' - 0". Four stabilizing headers spaced @ 2' - 4".
Connections: 2 x 6 Joists to the four 3 1/2" diameter PVC driven posts: two 3/8" diameter bolts, ea. post.

SKETCH OF DOCK FACILITY

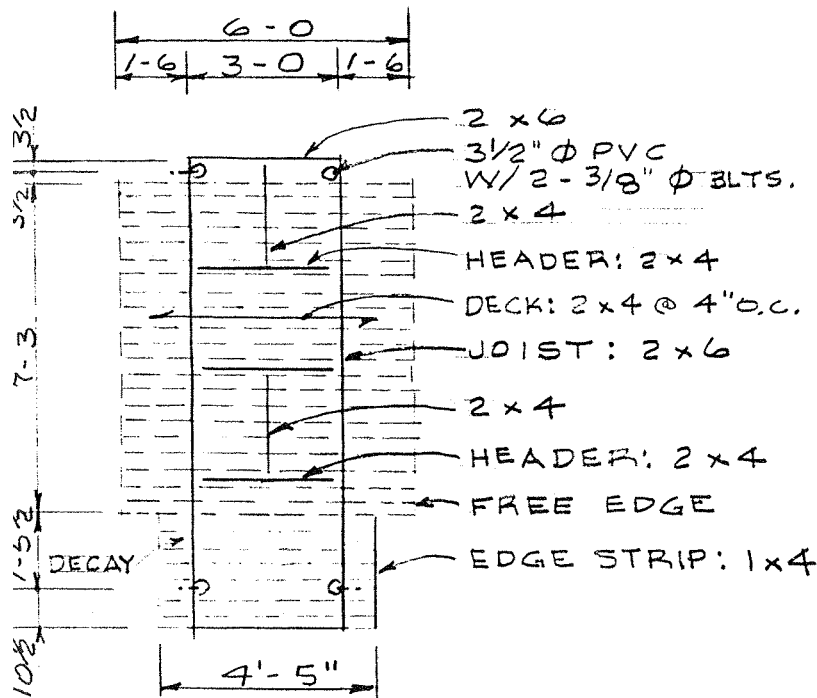

COMMENTS:

The 2x6 side joists spanning 9'- 0" are the members limiting the design capacity of this dock to 15 #/sq ft. Add edge strips to free ends of deck to provide combined action. Replace decayed 2x4 deck member. Doubling side joists will double capacity.

**GEM LAKES ESTATES
DOCK MANAGEMENT PROGRAM**

FIELD DATA: date 5/25/2002

NAME AND ADDRESS OF OWNER: William R. & Pauline Penland

221 Lakeside Drive

Aiken, S. C. 29803

Date of original application: 3/16/98 ; plans on file: yes; Photograph: no; Sketch: yes.

DOCK SIZE & ORIENTATION: width at shore: 6' - 0"; Dock length: 16' - 5". Projection: 18' - 0".
Ht above water 17"; There is no above dock construction.

DOCK CONSTRUCTION: type of materials and treatment: No. 1 SYP treated w/ 0.25 #/cu ft CCA.
Estimate of age and condition of materials: 6+ years; substructure is in good condition; the deck shows
some distortion from sun curl and a floating episode. Use $f=945$ psi in bending for existing and $f=1050$
for new materials

DOCK MATERIALS:

Deck planks: 2x6 @ 6" oc. max. span :3' - 2"; connections : 2 - 8d galv nails @ ea support.

Joists: size x spacing : 2x6 center @ 3' +/-; max span:8' 0". 4x4's ea. side, max span 8' - 0".

Header: 2x6 spanning 5' - 6"; Connection of 2 x 6 Joist to 2 x 6 header: galv steel seat clips.

Supports; 6 - 4x4 treated wood posts X - braced with 2x4's bolted to the posts. The posts are cast into
concrete footings bearing on the lake bottom. To offset buoyancy, use 2 cu ft conc. for ea post.

SKETCH OF DOCK FACILITY

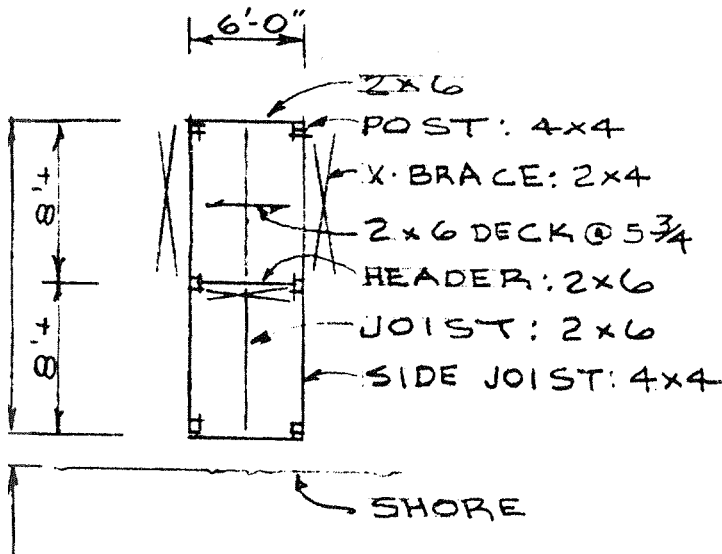

COMMENTS:

The 2x6 middle header joist spanning 5' - 6" is the member limiting the design capacity of the dock to 15 #/sq ft. The posts, bracing and side members of the dock have greater capacity and need not be replaced when the dock is reconstructed to eliminate the warping from the sun and floating episode. Recommended deck replacement: the deck members should be either 2x4 or 5/4 x 5 1/2 To provide 500 #/sq ft of load distribution capacity and with fewer warping traits. Replacement joists should be 2x6 spanning 8' - 0" and spaced @ 16" +/- . The center header should be 2 - 2x6's w/span of 5" - 6" for a load capacity of 40 #/sq ft. in the supporting frame.

**GEM LAKES ESTATES
DOCK MANAGEMENT PROGRAM
FIELD DATA: date 5/10/2002**

**NAME AND ADDRESS OF OWNER: W James & Judy Rivers
238 Springwood Drive
Aiken. S. C. 29803**

Date of original application: 3/16/98; plans on file: yes; Sketch: yes
Photograph: no

DOCK SIZE & ORIENTATION: width at shore: 11 ft 10 in; dock length: 12ft 0 1/2 in.;

Total projection from shore: 12 ft; Ht above water 18 inches; Size & location of handrails: none.

Other above dock construction: none

DOCK CONSTRUCTION: type of materials and treatment: No. 1 SYP treated w/ CCA

Estimate of age and condition of materials: 10 yrs; use 90% of "f" = 1050: = 945 psi

Deck planks: 5/4 x 5 1/2 @ 5 3/4" o. c. span: 24 inches connect. 2 - 8d nails ea joist.

Joists: size x spacing: 2x 6 @ 24" span: 12 ft w/ 2x6 bridging @ center of span

Connect. Joists to header: 1 1/2 x 1 1/2 ledgers on 2x6 perimeter headers

Headers: size x spacing 2x6 perimeter, max span = 8'.

Supports; 10 piling: Galv sheet metal posts filled w/conc & reinf w/ 4 #3 reinf. rods
3 concrete pads at the shoreline.

Connection to supports: 2 - 1/2" diam galv bolts @ ea post.

SKETCH OF DOCK FACILITY

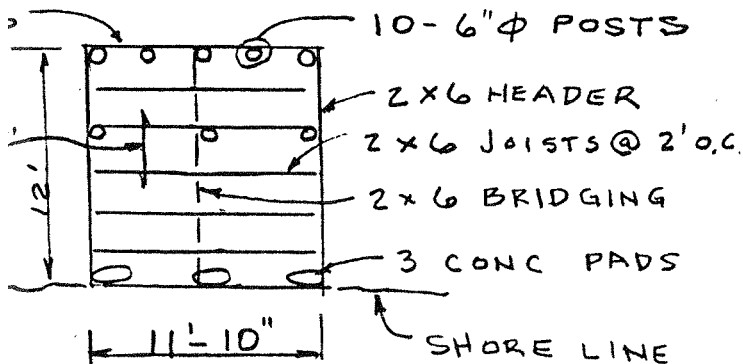

COMMENTS:

The 2x6 joists spanning 12 ft and the 2x6 header each side spanning 8 ft are the Members limiting the design capacity of this dock to approximately 15 lbs/ sq ft. To increase the capacity of the dock to 65 lbs/ sq ft, add 2 - 2x8's at the center col. to provide center line support of the 2x6 joists; also add a 2x10 to each of the 2 side headers.

**GEM LAKES ESTATES
DOCK MANAGEMENT PROGRAM
FIELD DATA: date 6/21/2002**

**NAME AND ADDRESS OF OWNER: Don and June Roseborough
245 Lakeside Drive
Aiken, SC 29803**

Date of original application: None ; plans on file: No; Photograph: no; Sketch: no.

DOCK SIZE & ORIENTATION: width: 12'- 5"; Dock length:8' - 0". Walkway width:3' - 0";
Walkway length: 24' - 0"; projection from water's edge: 22' +/- ; Ht above water 20" +/-; There are no
handrails or other construction above the level of the dock.

DOCK CONSTRUCTION: type of materials and treatment: No. 2 SYP for decking and No 1 SYP
for the joists; all timber is treated w/ 0.25 #/ cu ft of CCA. Estimate of age and condition of materials:
10 years in good condition; use f= 850 psi for the decking and 1080 psi for the support lumber.

DOCK MATERIALS:

Deck planks: 2" X 6" @ 5 3/4" oc , span: 2'-0"; connections : 2 - 8d galv nails @ ea support.

Joists: size x spacing : 2x6 @ 24" dock; & 2x6 @ 1' 10." walkway; span @ dock: 12' - 0"; span @
walkway 7' - 6"; connection of joist to headers: two 3/8" lag bolts in end grain.

Supports: 9 - 2 1/2" O D steel posts for the dock; walkway supports: 4 4x4 wood posts @ 7' - 6" oc.
Connection of the 2x6 perimeter members to the pipe supports: 2 - 1/4" U - bolts at ea steel post.
Connection of the walkway joists to the wood posts: 2 - 3/8" bolts.

SKETCH OF DOCK FACILITY

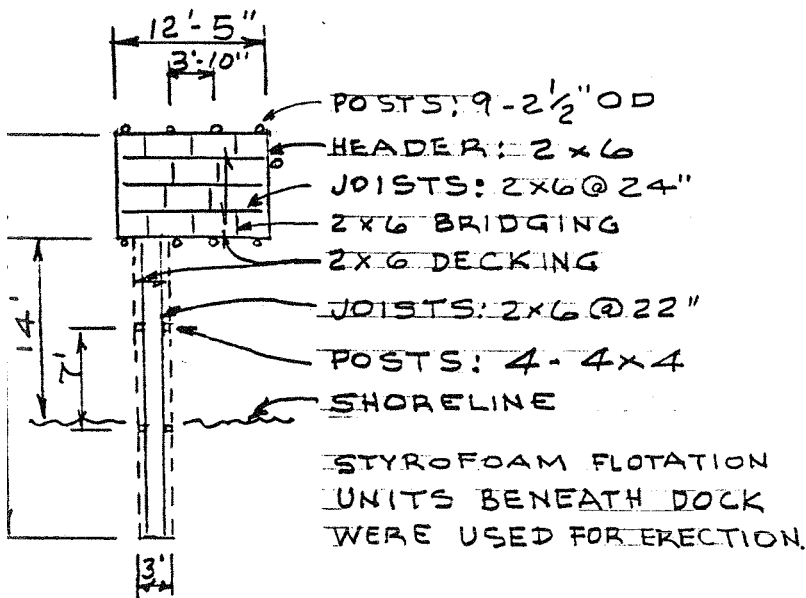

COMMENTS:

The 2x6 joists @ 24" & spanning 12' have an estimated load capability slightly greater than 15 #/ sq ft. The 2x6 headers limit the dock capacity to slightly less than 15#/sf. Adding a 2x10 to each of the end headers will substantially improve the load capability of the dock. Adding a support at the center of each end header also will provide a similar benefit. When the decking is replaced, change the joists to 2x8s to replace the 2x6's spanning 12 ft.

GEM LAKES ESTATES
DOCK MANAGEMENT PROGRAM
FIELD DATA: date 5/10/2002

NAME AND ADDRESS OF OWNER: Dan Wood and Malcolm Kyle

268 Springwood Dr. & 274 Springwood Dr.

Aiken, S. C. 29803

Date of original application: 3/16/98 ; plans on file: yes; Photograph: no; Sketch: yes.

DOCK SIZE & ORIENTATION: width at shore: 7' 10 1/2"; Dock length: 19' - 6". Projection: 19' - 0".

Ht above water 11"; There are no handrails or other above dock construction. ("no swimming" sign).

DOCK CONSTRUCTION: type of materials and treatment: No. 1 SYP treated w/ CCA.

Estimate of age and condition of materials: 5 years in good condition; use $f = 1050$ psi in bending.

Dock:

Deck planks: 2x8 @ 7 3/4" oc. span : 3 ft & 1 ft cantilever; connect : 2 - 8d screw nails @ ea support.

Joists: size x spacing : 2x4 center @ 3' ; max span: 4' - 6". 2 - 2x6's outside posts, max span 9' - 2"

Connect. 2 x 4 Joist to 2 x 6 header: ledger; connect 2 - 2x6 to post: 4 - 20d galv nails.

Headers: 2x6 @ max spacing of 4'-6"; span: 5' - 2" ; 2x4 corner bracing near posts.

Supports; piling: 6 treated wood posts, 10" diameter; Connection to posts: 4 - 20d galv nails.

SKETCH OF DOCK FACILITY

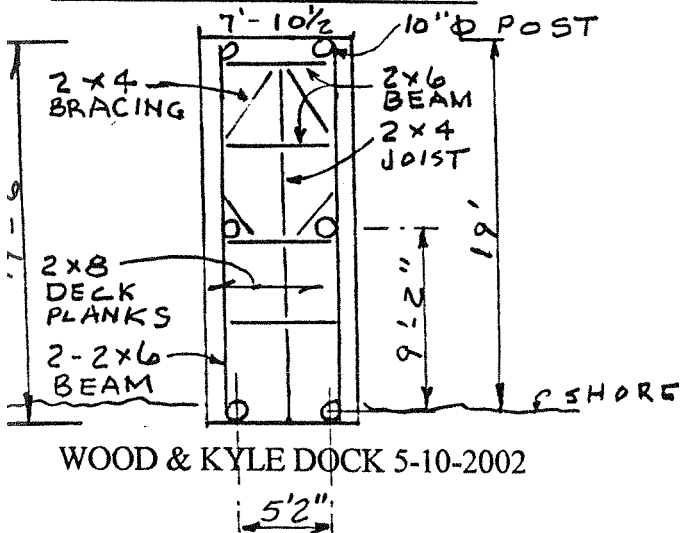

COMMENTS:

The 2 - 2x6 exterior beam spanning 9'-2" is the member limiting the load capacity of this dock to 30 lbs/ sq. ft. The use of 2x8 deck planks has substantially increased sun curl of the deck over that resulting from the use of 4" wide or 6" wide planks.